



Leva la Leva Tyre changer  
Artiglio Master Jolly

# The heart of technology. No compromises

The quality of the Corghi Master line.



Version with MANUAL wheel clamping



TECHNOLOGY  
PARTNER  
product



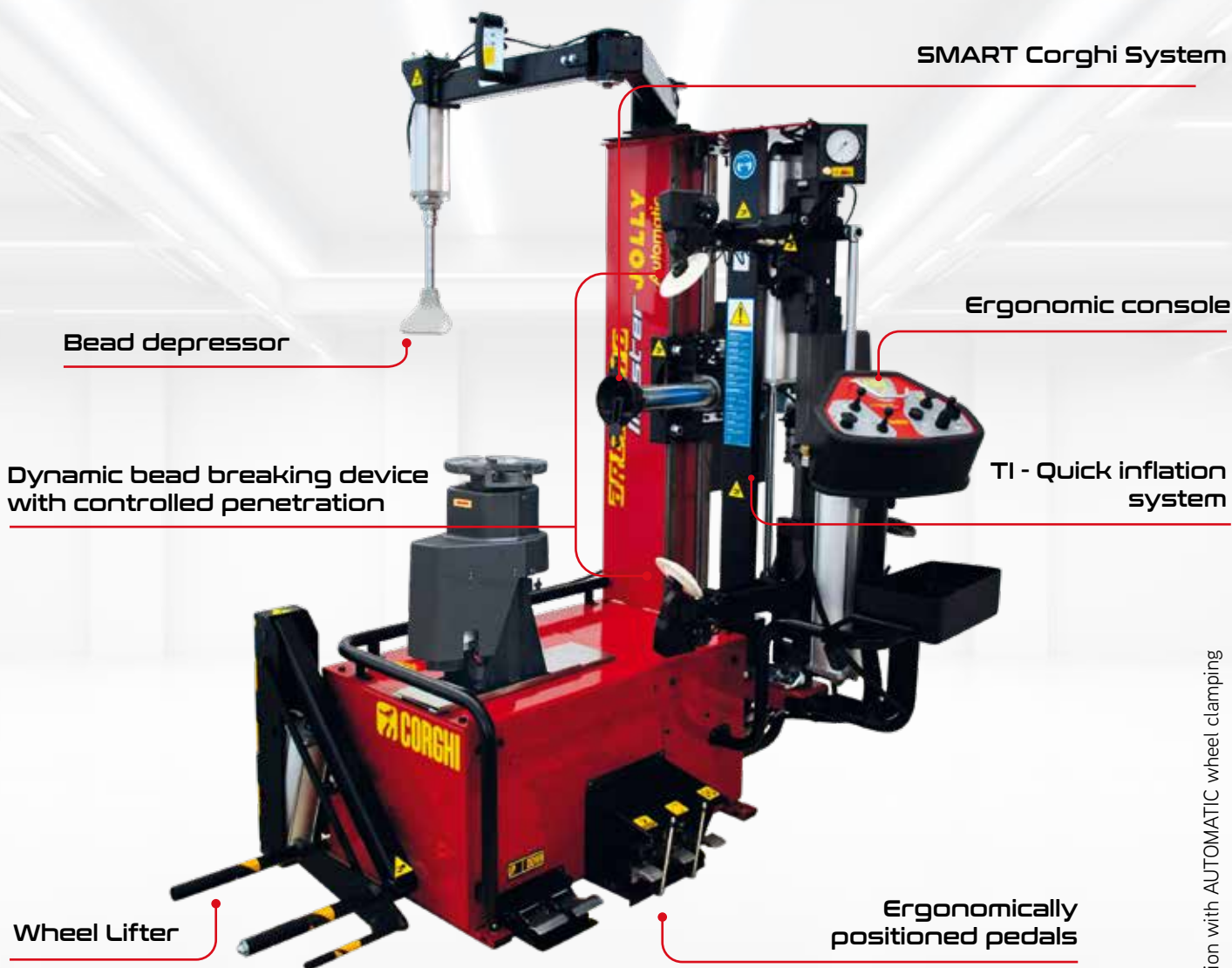

Version with AUTOMATIC wheel clamping

## Main features

Since 2001, the year our “Leva la leva” technology was introduced, many hurried to chase after us, presenting their own solutions. They called their solutions “no lever”, or “leverless”, or the “automatic lever system”. The truth is however that no one has been able to copy the patented “Leva la leva” system with the “SMART Corghi System” device, the only existing solution that:

- **NEVER TOUCHES THE RIM**, during any working phase
- **annuls all tension on the tyre during the tyre demounting/mounting phases.**

**This is the difference between Corghi and the others.**

Artiglio Master Jolly has this technology at its core and offers it in a price range that has been impossible until now. A perfect synthesis between tested constructive quality, unique technological solutions and a competitive price represents the ideal machine and a perfect balance for an investment that since 2001 has guaranteed our customers a technological advantage that has remained unmatched over time.

**NOT ALL LEVA LA LEVA SOLUTIONS ARE EQUAL!** And we are well aware of this.

**ALSO AVAILABLE IN “AUTOMATIC” VERSION**

## SMART Corghi System

### The heart of the "Leva la Leva" technology

No one has been able to copy the patented **SMART Corghi System**.

**NEVER TOUCHES THE RIM**, during any working phase, thanks to the fixed distance between the tool and the rim

**ANNULS ALL TENSION ON THE TYRE** during the tyre demounting/ mounting phases, thanks to the synchronised movement between the tool and the rim

THIS IS THE DIFFERENCE BETWEEN CORGI AND THE OTHERS.  
THIS GUARANTEES A **TECHNOLOGICAL ADVANTAGE THAT HAS REMAINED UNMATCHED OVER TIME**

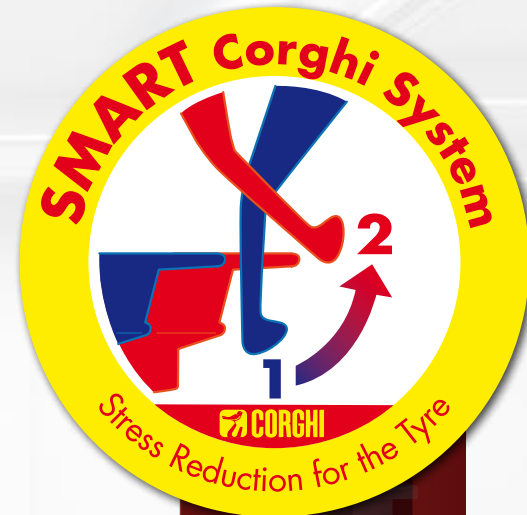

Watch the video





## Console

**Ergonomic** and **multifunctional** consoles with a display that makes it possible to electronically set the rim diameter and obtain the horizontal positioning of the work tools in a quick, practical and safe manner. **Divided into three distinct work areas**, it makes it easier to immediately recognize movements and makes the system easier to use for the operator.

## Dynamic bead breaking device with controlled penetration

- **Dynamic bead breaking device** with dual specular bead breaker disc. The radial positioning of the discs is made easier by an automatism that is able to prevent any manual positioning by the operator.
- **Controlled penetration** (Patent Pending) Precision, rapidity and repeatability are guaranteed by the patented bead breaking system and by the perfectly synchronized and symmetrical motions of the two discs.
- **Enhanced bead breaker force** to operate effectively on all types of tyres.



Watch the video

## Rapid bottom bead demounting procedure

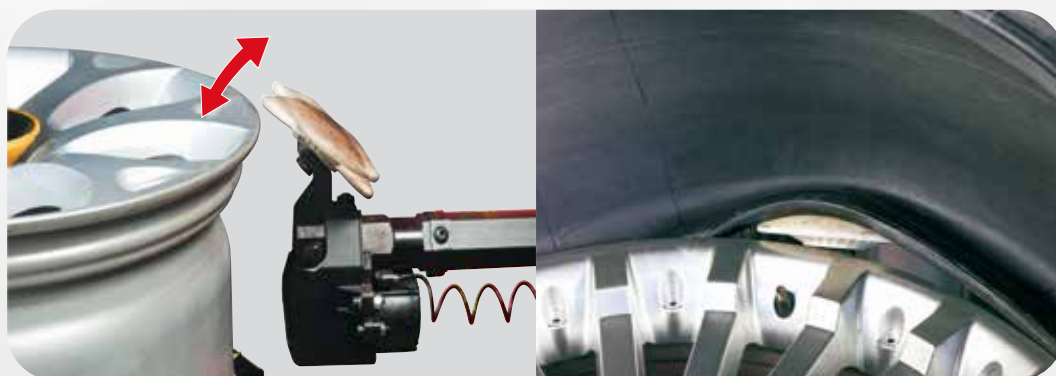

Rapid demounting procedure with bead breaker disc (particularly useful with stiff sidewalls)

## “AUTOMATIC” VERSION WITH ELECTRO-MECHANICAL WHEEL LOCKING

The “**AUTOMATIC**” version offers the same electro-mechanical locking system currently used on top-of-the-range models: Master CODE Plus and Master Force.

The **ELECTRO-MECHANICAL** locking system represents an important feature for everyday tire service operations. It is a wheel locking system recognized as the most high-performing and professional available on the market.

Its use is **simple** and intuitive. **Safe** and **reliable**.

### Key benefits of the new wheel locking system

- Increased performance of the most iconic Master models of the Corghi brand.
- More precise, reliable, and uniform wheel locking, in line with the high standards that distinguish the Master series.
- Locking with dedicated torque control ensures perfect wheel clamping and guarantees that all wheels are tightened in the best possible way.



## VERSION WITH MANUAL WHEEL CLAMPING

### Safe and universal wheel clamping.

The axial mounting turntable ensures rapid clamping while permitting bead breaking on both sides without having to turn the wheel itself. The constant working height (reverse rims excluded) has been optimised for **ideal operator ergonomics** with all wheel types, reducing physical effort.



## Bead depressor

- Bead depressor with adjustable working height
- Depressor shape ideal for RFT tyres
- Standard in all versions



## Ergonomics

**Fixed work position:**  
pedals, consoles and wheel loading on the same side.

**Constant working height**  
for perfectly ergonomic movements.



## Wheel Lifter

A wheel lifter for effortlessly placing wheels of any type onto the turntable (optional accessory).

## Standard Accessories

### Manual wheel clamping version



### "Automatic" version



## Recommended Accessories

#### 8-15100003

Special adapter kit for high rims (H=28mm).  
E.g. Porsche rear wheel

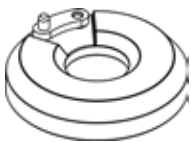

#### 8-15100040

Spacer ring kit H=22mm  
matches with 8-11100037 / 8-11100086 / 8-15100003



#### 8-11100037

Van and pick-up rim rise kit for AUTOMATIC locking

#### 8-11100086

Van and pick-up rim rise kit for MANUAL locking



#### 8-11400340

TI - Quick inflating system kit

#### 8-11400341

TI - Quick inflating system kit ASME (for USA and Canada)



#### 8-15100041

Universal flange ALL IN ONE  
h 100 mm + 20 mm spacers  
(min-max wheelbase - PCD :  
95-183 mm / 3.7"-7.2")



## TECHNICAL SPECIFICATIONS

## WHEEL DIMENSION RANGE

RIM DIAMETER	12" ÷ 26"
MAXIMUM TYRE DIAMETER	1100 mm (*)
MAXIMUM TYRE WIDTH	360 mm (14")*
TYRE TYPES PROCESSED	CONVENTIONAL, LOW PROFILE AND RUN FLAT

## TURNABLE

CLAMPING	MANUAL - ELECTROMECHANICAL ON "AUTOMATIC" VERSION
DRIVE SYSTEM	2 SPEED MOTOINVERTER
ROTATION TORQUE	1100 NM
ROTATION SPEED	7 - 18 rpm

## BEAD BREAKER

MAXIMUM BEAD BREAKING RANGE	18"
BEAD BREAKER STROKE	450 mm
BEAD BREAKER FORCE	7600 N

## WHEEL LOADING / UNLOADING

OPERATION	PNEUMATIC
MAX WHEEL WEIGHT	85 KG

## POWER SUPPLY

ELECTRIC 1PH	230V - 0,75 KW - 50 HZ
ELECTRIC 1PH (ALTERNATIVE)	110V - 0,75 KW - 60 HZ
PNEUMATIC OPERATING PRESSURE	8 ÷ 9,5 BAR (MIN.)
WEIGHT	440 KG (TI = 455 KG)
PACKAGING (L X D X H)	1240x1500x1840 mm
PACKAGING WEIGHT	440 KG (TI = 455 KG)

## DIMENSIONS

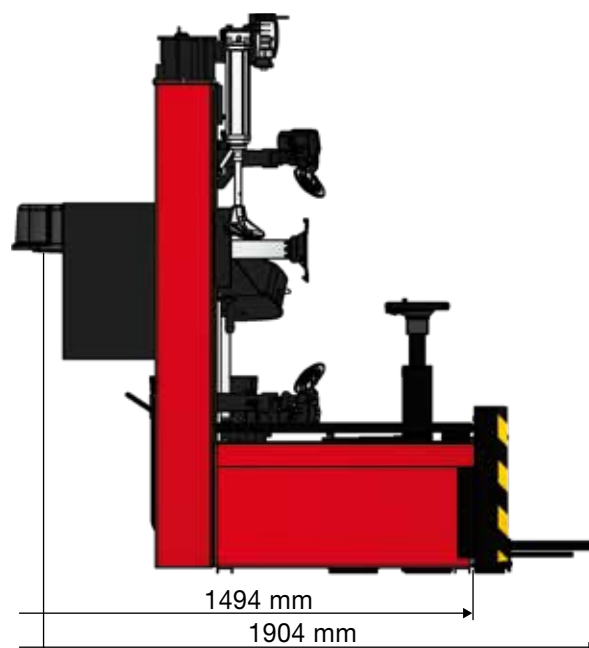
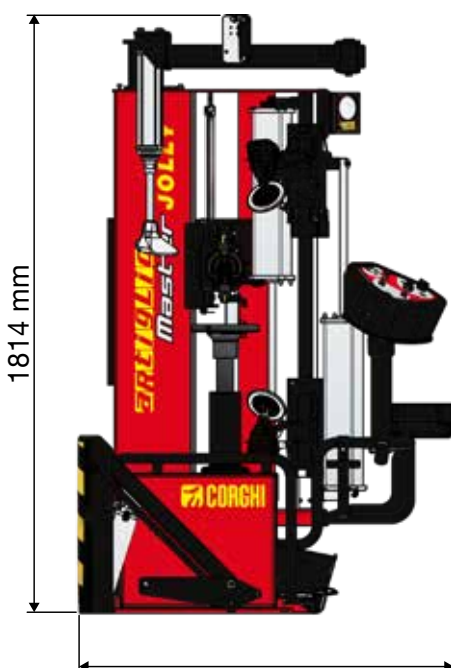

Watch the video

Watch the video  
"The Birth"

www.corghi.com

CORGHI is a brand of the NEXION spa group

Via Strada Statale 468, n. 9 - 42015 Correggio (RE) | +39 0522 639111 | info@corghi.com

